

# Product Datasheet

## LED High-Bay Luminaire



### Areas of applications

- Warehouses, factories.
- Industrial and commercial halls.
- Storage facilities.
- Public areas.

### Product Features

- Luminaire efficacy up to 140 Lm/W.
- Life time 50 K hours (L80).
- Class I Protection.
- Ingress of Protection: IP66.
- Failure rate less than 10%



## Technical Data

Manufacture	<b>AL HODA Electric ( Storm LED )</b>
Input Power	<b>200 W</b>
Input Voltage Range	<b>85 – 305 V</b>
Power Factor	<b>&gt;=0.97</b>
Input Current	<b>&lt; 1 A</b>
Total Harmonic Distortion (THD)	<b>&lt;=10%</b>
Frequency Range	<b>47-63 HZ</b>
Driver	<b>Philips Xitanium LED Driver</b>
Driver Efficiency	<b>94.5%</b>
Luminaire Efficacy	<b>130 ~ 140 Lm/W</b>
LED Type -Efficiency	<b>Lumileds – 170 Lm/W</b>
Output Lumen	<b>26000~28000 LM</b>
Color Rendering Index (CRI)	<b>Ra&gt;=80%</b>
Color Temperature (CCT)	<b>5000 K – 6500 K</b>
SDCM	<b>1-3 Steps</b>
Beam Angle	<b>120°</b>
Ambient Temperature&Humidity	<b>-40°C to +60°C 10% to 90%</b>
Protection	<b>Over Voltage Protection Under Voltage Protection Over Load Protection Surge Protection 6 KV Over Temperature Protection</b>
Ingress of Protection	<b>IP66</b>
Fixture Weight	<b>6.12 Kg</b>
Order	<b>SOM-SL-HB-UFO-200W</b>

All values typical unless otherwise stated (tolerance +/- 5%) @25°C

## Dimensions

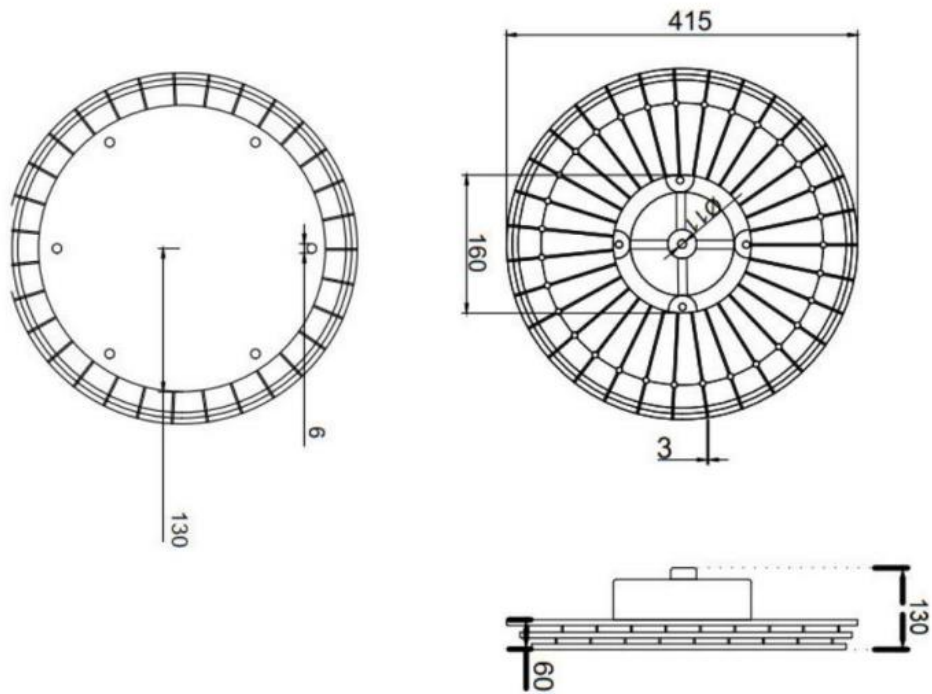

## SOM-SL-HB-UFO-200W

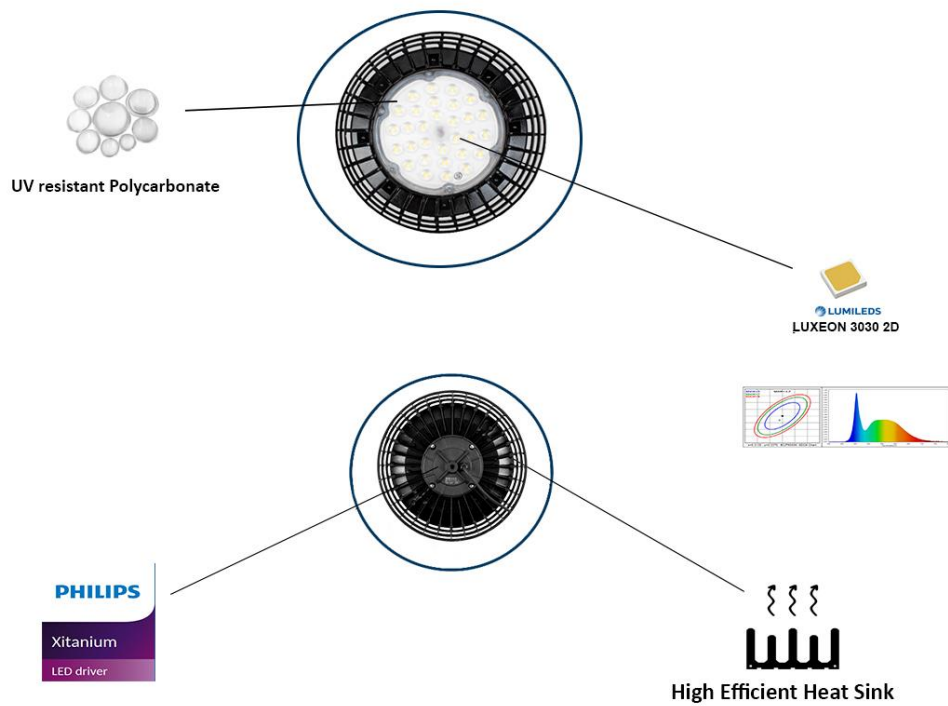

## Contact US

- **Alhoda Electric Factory and administration building.**

Block IXQ, Third Industrial zone A1, 10<sup>th</sup> of Ramadan, Sharqia, Egypt.

**Tel: +20 55 4411096**

**Fax: +5 (5) 441 0734**

**Customer Service: +2 (0) 106 567 7999**

**+2 (0) 100 767 0179**

**+2 (0) 106 016 6689**

**+2 (0) 105 086 1336**

**Email: [sales@stormelectric.org](mailto:sales@stormelectric.org)**

- **Our showroom:**

Egyptian center 1, Exhibition 58, Jordanian square, 10<sup>th</sup> of Ramadan, Sharqia, Egypt.

**Tel: +5 (5) 436 1394**

**Customer Service: +20 100 666 1498**

**+20 102 287 3111**

**Email: [sales@stormelectric.org](mailto:sales@stormelectric.org)**



**<http://www.facebook.com/StormElectricEg>**



**<http://www.linkedin.com/company/70401773/>**



**<http://www.instagram.com/stormelectriceg/>**